



Hammer Mill

From dry saw dust to powder



Hammer Mill Type BNA50



Hammer Mill

type ⇄ BNA 50 ⇄

BNA 100
BNA 150
BNA 200



High Quality
High efficiency

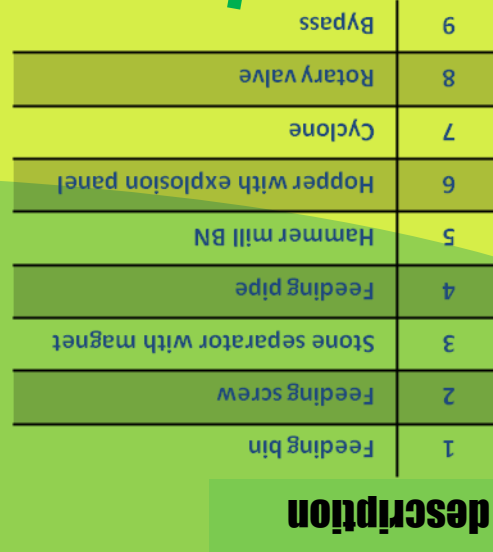

description

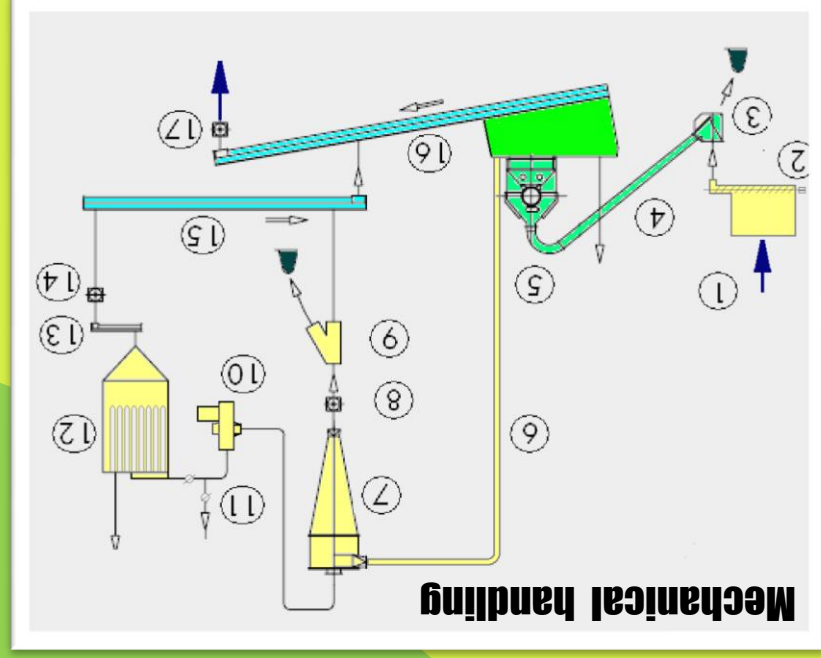

description

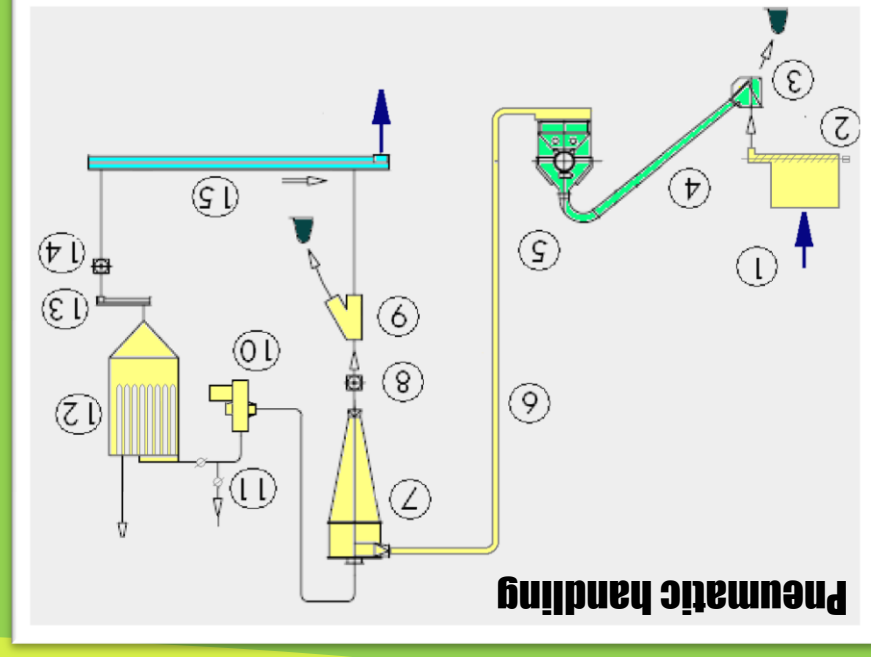

description

10	Fan
11	By pass
12	Filter
13	Screw
14	Rotary valve
15	Screw
16	Screw
17	Rotary valve



Hammer Mill Type BNA50



Hammer Mill Type BNA50



- HIGH CAPACITY
- LOW ENERGY CONSUMPTION
- DIRECT OR INDIRECT COUPLING
- BI-DIRECTIONAL ROTOR
- NUMEROS FEEDING SYSTEM

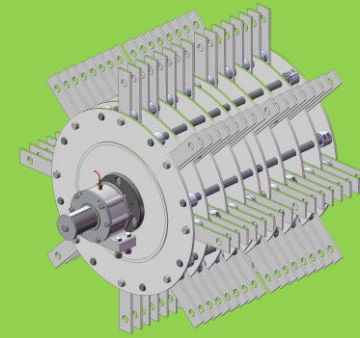

- Heavy duty rotor
- Easy hammer replacement
- High speed (109 m/s)

- Large range of screen
- Largest screen surface
- Easy and quick screen exchange

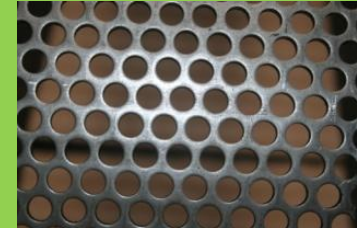

- 2 or 4 sides Hammers
- Extreme long lasting Hammers
- Easy and quick hammer exchange

Capacities

Ø mm	Power kW	Micro chips 3 x 50 mm	Saw dust
1	250 -500	1-2 T/H	2-3 T/H
2	250 -500	2-3 T/H	3-4 T/H
3	250 -500	3-4 T/H	4-5 T/H
4	250 -500	4-5 T/H	5-6 T/H
5	250 -500	5-6 T/H	6-7 T/H
6	250 -500	6-7 T/H	7-8 T/H

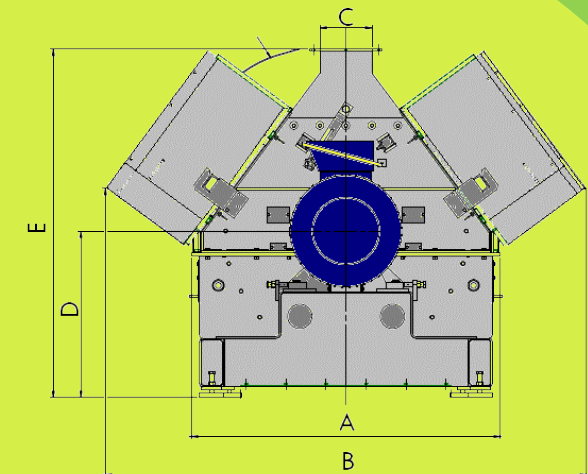
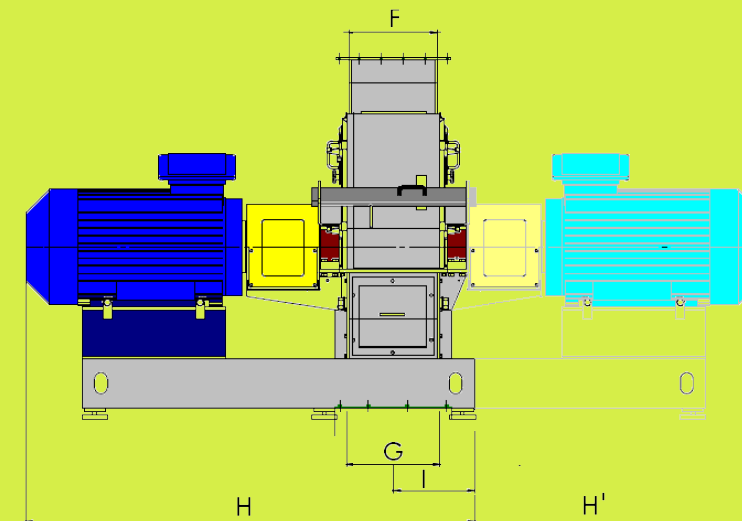
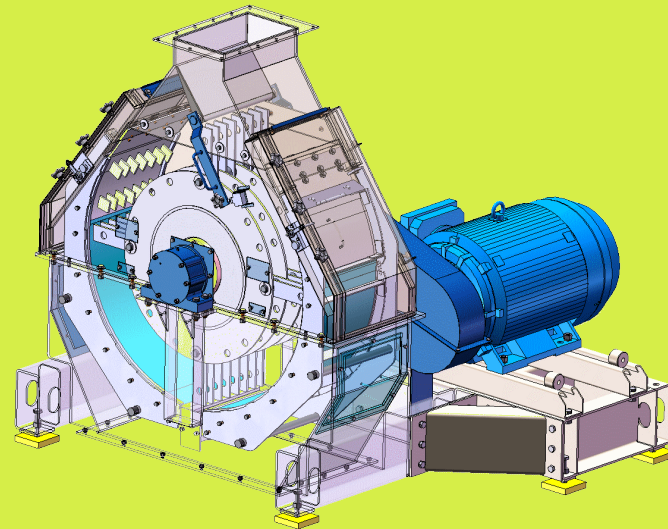

Main data

rotor		Screen		Hammers		Hammer mill		
Ø mm	Width mm	surface m ²	Number	Number	Weight Kg	Power kW	Weight Kg	Air volume M ³ /h
1 384	500	1.5	2	32-128	1.95	132-315	4 900	9000 -14 000

Dimensions (mm)

A	B	C	D	E	F	G	H	H'	I
1 900	3 090	320	1 025	530	530	560	2 320	650	500